

# OUR PRODUCTS

Trailers, compatible swap-body platforms and load aids



Truck turntable-trailers



Truck semi-trailers



Truck tandem-trailers



Truck dolly-trailers



Car and pickup truck trailers



Accessories

## TRANSPORTATION SOLUTIONS FOR TIMBER HOUSE CONSTRUCTION

Telescopic, expandable and equipped with a uniform Stanchion system for wall element transport up to 30 t - Our exchange systems and loading aids solve the logistical core problems of modern carpenters and prefabricated timber house builders.

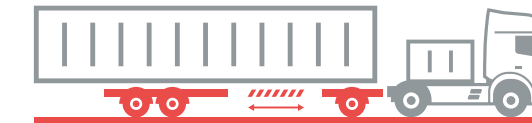

## TURNTABLE TRAILERS

# TL-FG SERIES

LOWEST LOAD HEIGHT, MAXIMUM TRANSPORT LENGTH – THE STRONG TURNTABLE TRAILER WITH TELESCOPIC EXTENSION.



**Auwärter**  
TELE-CARGO-SYSTEMS

Auwärter – Anhänger und Aufbauten GmbH & Co. KG  
Harlachhammer 2  
D-95679 Waldershof

[www.auwaerter.com/en](http://www.auwaerter.com/en)

**Auwärter**  
TELE-CARGO-SYSTEMS

# KEYFACTS

Things to know about your new Auwärter

The TL-FG Series was specially developed together with our customers for the requirements of long material transport. Its telescopic chassis makes it suitable for flatbed swap-body platforms to be accepted and transported. A turntable platform extends the load surface by an additional 2 m.

Alongside the particularly low load height with an accepted swap-body platform, handling of load and load system turns out to be surprisingly simple. Two longitudinal members allow controlled insertion into the swap-body frame with the chassis. In restricted building areas, the TL-FG is convincing with its enormous maneuverability.

# FEATURES

**1 PATENTED TOWING FORK**  
dropped for the lowest load height

**2 DUAL TIRES**  
make a lower load height possible

**3 EXTENDABLE CHASSIS**  
Variable extension by 3 m lengthwise

**4 AIR SUSPENSION**  
with raising and lowering, 3 axle unit

**5 CONTAINER LOCKING**  
for securing when attaching the swap-body platform

**6 ETS STEERING SYSTEM**  
Steering with positioning option and maximum steering angle up to 22 degrees

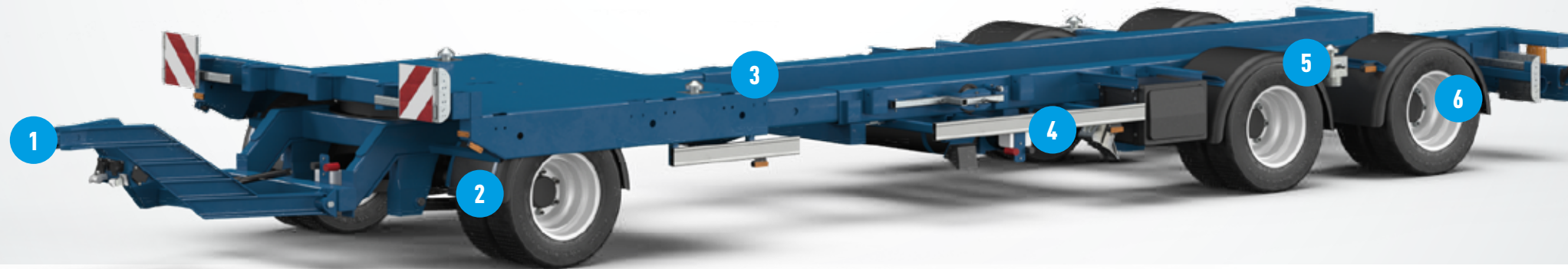

## COMPATIBLE SWAP-BODY FRAMES

Made for long material transport – the extending flatbed platforms TLP190, TLP200 und TLP240.



## ADVANTAGES

- > Transport of particularly long material and timber house walls
- > The lowest load height with inserted swap-body platform of 810 mm
- > Precise approach and insertion of the swap-body platform thanks to longitudinal guides
- > Exceptional following characteristics and maneuverability
- > EPD coating (sand blasted + cathodic immersion priming + coating in RAL colors)

## TECHNICAL DATA

With a payload of up to 18.5 t and load lengths of up to 13 m, the TL-FG Series is particularly suitable for transporting heavy long material.

	TL190FG	TL200FG	TL240FG
GROSS WEIGHT	19,500 kg	20,000 kg	24,000 kg
PLATFORM WIDTH	approx. 2,550 mm	approx. 2,550 mm	approx. 2,550 mm
PLATFORM LENGTH	approx. 7,000 - 10,000 mm	approx. 7,000 - 10,000 mm	approx. 7,000 - 10,000 mm
PAYLOAD STANDARD	approx. 14,000 kg	approx. 16,500 kg	approx. 18,500 kg
LOAD HEIGHT	approx. 810 mm (loaded)	approx. 880 mm (loaded)	approx. 850 mm (loaded)
TIRES	Dual 205 / 65 R 17.5	Dual 235 / 75 R 17.5	Dual 215 / 75 R 17.5

## ACCESSORIES



**TELESCOPIC EXTENSION TL/FG**

- > Extending chassis by up to 3 m
- > with automatic guide rollers and pneumatic locking



**SAFETY PACKAGE**

- > Oversized warning signs front and rear
- > Side LED lighting
- > LED Perimeter lighting that can be plugged in at the rear

### AUTOM. ELECTRO-HYDRAULIC STEERING SYSTEM

- > Steering axle and hydraulic steering cylinder
- > Slewing ring with pulsed angle sensor
- > Remote control for manual control

### CROSS MEMBER LASHING RAIL

- > Cross members with lashing bars and stanchion bars 60x60 mm
- > Hot-dip galvanized

### S STAKES

- > QuRo 80x80 secured with pins
- > Hot-dip galvanized
- > Height optionally approx.: 1,200 mm – 2,000 mm

### TRANSVERSE MEMBER FOR CONSTRUCTION TIMBER

- > Insertable and lockable
- > Suitable for long timber transport
- > Hot-dip galvanized
- > X stake pockets and lashing possibility centrally at the sides

### FLOOR IN THE LOW BED

- > Aluminum corrugated sheet
- > Stake pockets along the length